

Interactive Adapter search:
www.mactoolsradiatortools.com

SCAN
THIS CODE



CST500

Includes 3 Most Commonly Required
Cooling System Adapters



MAR100

Coolant Retainer and
Pressure Tester



CSR202

For Use with Positive
Fit Cooling System Adapters

Higher Vacuum!
**Faster, more
complete fill!**



CSR302

No Adapters Required!

APPLICATION GUIDE and PARTS LIST for
COOLING SYSTEM ADAPTERS and COOLING SYSTEM TOOLS

MAR
TOOLS

COOLING SYSTEM TOOLS FOR LARGE TRUCKS



CSR400

Truck Refiller sized specifically for large trucks

CSR400 Large Truck Refiller

- New higher capacity generator creates a high vacuum quickly.
- Larger internal passageways to move more coolant faster
- Longer and larger hoses improve coolant flow
- Faster, more complete fill on larger systems



CST300 Large Truck Cooling System Pressure Tester:

1. Pressure pump uses shop air to generate pressure in large truck cooling systems EFFORTLESSLY!

2. Set includes 3 adapters to pressure test pressure relieving caps found on large trucks. The UCT700-6 cap adapter tests caps from "A" size (2 3/16" O.D.) filler necks. The RCA14504 cap adapter tests caps from "B" size (2 11/16" O.D.) filler necks. The RCA1C035 cap adapter tests caps with a 52mm x 2.5mm thread.

Combine CST300 with CSA600 for complete truck cooling system testing with no duplications.

CSA600 Large Truck Cooling System Adapter Set:

Compatible with most cooling system pressure tester pumps. Includes 6 cooling system adapters:

- (1) RA14505
- (2) RA10036
- (3) RA10027
- (4) RA10022
- (5) RA10054
- (6) RA10032

NOTE: Plastic box available separately #CSA600PB



RA10022



RCA1C023



WHERE GASKET OF CAP SEALS ON COOLANT BOTTLE NECK

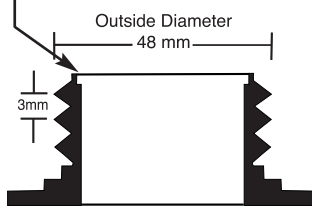

Thread Cutaway

APPLICATION:

AUDI®: models with male threads on filler neck
PORSCHE®:
Boxster: 1997-2006
Cayman: 2006
911: 2000-2012
SMART CAR®:
Models 2008-2015
VOLKSWAGEN®: models with male threads on filler neck of radiator or expansion tank-pre 1990.

RA10025



RCA1C026



WHERE GASKET OF CAP SEALS ON COOLANT BOTTLE NECK

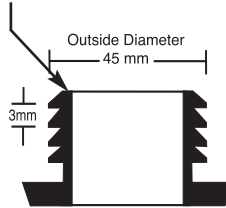

Thread Cutaway

APPLICATION:

FERRARI®/MASERATI®: most models 2000-current
JEEP®: models with male threads on filler neck (1990-1994)
RENAULT®: (1985-1997)
SAAB® 900: (1978-1993)
-900 Convertible (1994)
-9000 (1986-1998)
STERLING®: (1987-1991)
VOLVO®: most models through 2007 with threaded neck (see page 18)

RA10031



RCA1C030



WHERE O-RING OF CAP SEALS ON COOLANT BOTTLE NECK

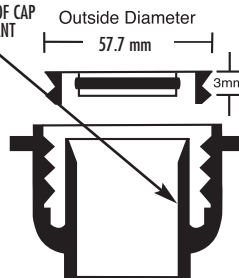

Thread Cutaway

APPLICATION:

VOLKSWAGEN®:
Most models with female threads on filler neck 1990-1998

RA10032

RCA1C035



WHERE GASKET OF CAP SEALS ON COOLANT BOTTLE NECK

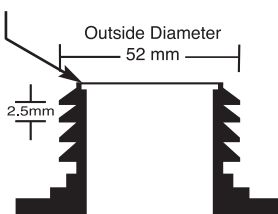

Thread Cutaway

APPLICATION:

Some models of Buick®, Cadillac®, Chevrolet®, Ford®, Freightliner®, GMC®, International®, Infiniti®, Isuzu®, Jaguar®, Kenworth®, Land Rover®, Lincoln®, Mazda®, Mercedes®, Mercury®, Nissan®, Oldsmobile®, Peterbilt® and Pontiac®.

RCA1C047



RA10034



RA10034



WHERE GASKET OF CAP SEALS ON COOLANT BOTTLE NECK

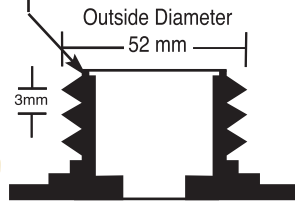

Thread Cutaway

APPLICATION:

Some models of Cadillac®, Chevrolet®, Daewoo®, Ford®, Jaguar®, Land Rover®, Pontiac®, Saab®, Saturn® and Suzuki®

RCA1C035



RA10036



WHERE O-RING OF CAP SEALS ON COOLANT BOTTLE NECK

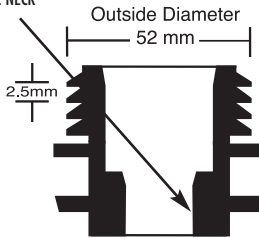

Thread Cutaway

APPLICATION:

Some models of Buick®, Cadillac®, Chevrolet®, Dodge®, Ford®, Freightliner®, GMC®, Hummer®, International®, Infiniti®, Isuzu®, Jaguar®, Jeep®, Land Rover®, Lincoln®, Mazda®, Mercedes®, Mercury®, Nissan®, Pontiac®, RAM®, Saab®, Saturn® and Suzuki®

RA10041



RCA1C040



WHERE O-RING OF CAP SEALS ON COOLANT BOTTLE NECK

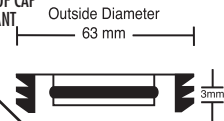

Thread Cutaway

APPLICATION:

AUDI®: A4 1996-current
A6 1998-current
A8 1997-current
S4 2004-current
TT 2000-current

BENTLEY®: 2006-current
LAMBORGHINI®: 2006-current
PORSCHE®:

Boxster 2007-2013
Cayenne 2003-2013
Cayman 2007-2011
Macan 2015-current
Panamera 2010-current

VW®: most models, 1998 and newer

RCA1C045



RA10044



WHERE O-RING OF CAP SEALS ON COOLANT BOTTLE NECK

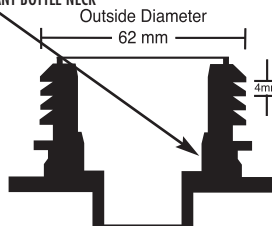

Thread Cutaway

APPLICATION:

MERCEDES-BENZ®: with threaded filler neck on expansion tank (except M-class, 1998-2005) (see page 16)
Sprinter Van 2019-current

CHRYSLER®:

Crossfire 2004-2008

RCA1C047



PAGE 4



RA10046



RA10046



WHERE O-RING OF CAP SEALS ON COOLANT BOTTLE NECK

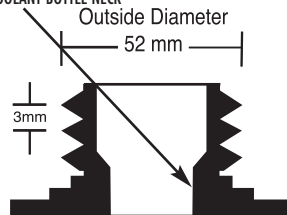

Thread Cutaway

APPLICATION:

Some models of Aston-Martin®, Ford®, Jaguar® and Mazda®

RCA1C049



RA10048



WHERE O-RING OF CAP SEALS ON COOLANT BOTTLE NECK

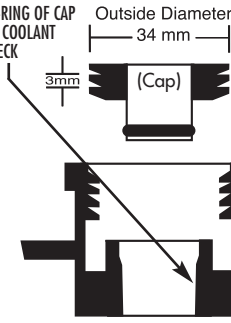

APPLICATION:

- LEXUS®:**
 - LS 2007 - current
- LOTUS®** Some Models
- TOYOTA®:**
 - Calica 2000-current
 - Spyder (MR2) 2000-current
 - RAV4 2009-current
 - Hybrid Synergy Drive
- Cooling System:**
 - Prius 2004-current
 - Camry 2007-current
 - Highlander 2006-current
- SCION®:**
 - XB, 2008-current

RCA1C053



RA10052



WHERE O-RING OF CAP SEALS ON COOLANT BOTTLE NECK

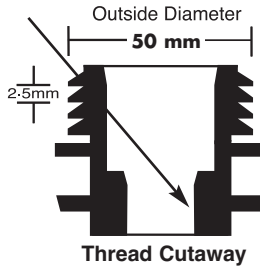

APPLICATION:

- ASTON MARTIN®:**
 - 6.0L, V-12
 - 2015-current
- FORD®:**
 - Many of the newer models (2011 and newer) will take the RA10052. See page 13 and 14 for specific models.
- LAND ROVER®:**
 - LR-2 2008-current
 - Range Rover
 - Evoque 2012-current
- MAZDA®:**
 - Mazda 3 2004-current
- VOLVO®:**
 - most models 2004-current

RCA1C057



RA10056



WHERE O-RING OF CAP SEALS ON COOLANT BOTTLE NECK

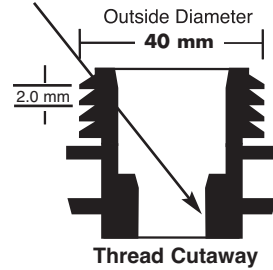

APPLICATION:

- Supercharger Cooling Systems
- CADILLAC®:**
 - STS, ATS, CTS 2006-current
- CHEVROLET®:**
 - Cobalt SS 2005-2007
- CHRYSLER®:**
 - Pacifica Hybrid 2017-current
- SATURN®:**
 - Ion Redline 2004-2007

RCA1C059



RA10058



WHERE O-RING OF CAP SEALS ON COOLANT BOTTLE NECK

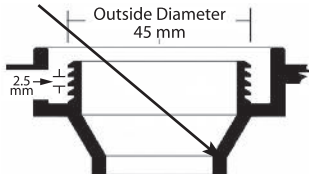

APPLICATION:

- DODGE®:**
 - Sprinter Van 2007-2010
- MERCEDES®:**
 - Sprinter Van 2011-2018
 - A-Class 2019 - current
 - B-Class 2015 - current

RCA1C026



RA10063



WHERE GASKET OF CAP SEALS ON COOLANT BOTTLE NECK

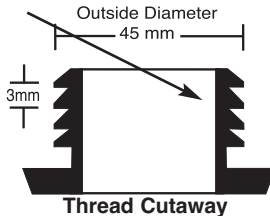

APPLICATION:

- BMW®:**
 - Turbocharger Cooling Systems (all)
 - INFINITI®:**
 - QX 50 2019 - current
 - MINI®**
 - Cooper 2002-current
 - SMART CAR®:**
 - 2016-current
- Comment: The RA10063 seals with an o-ring just like the cap from the system it tests. In most cases, the RA10025, which seals on the top rim will adequately seal such that pressure testing can be accomplished.*

**KTM® MOTORCYCLES
BAYONET STYLE
ADAPTER**

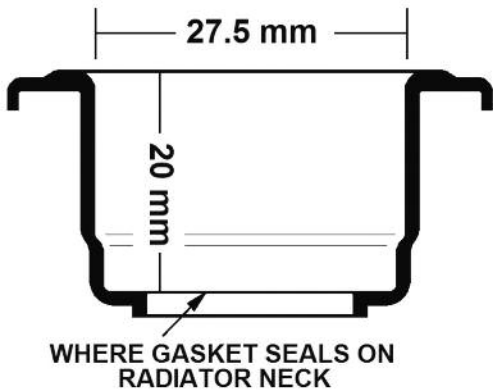

**KTM® MOTORCYCLES
THREADED
ADAPTER**



WHERE GASKET OF CAP SEALS ON RADIATOR NECK

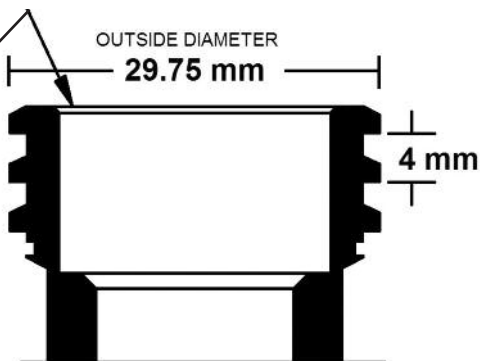

**APRILIA® MOTORCYCLES
THREADED
ADAPTER**

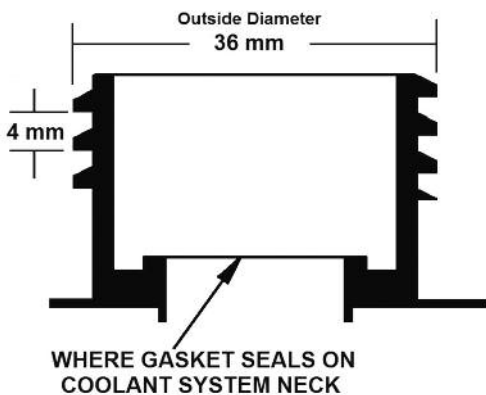

RA10072

RCA1C026



WHERE GASKET OF CAP SEALS ON COOLANT BOTTLE NECK

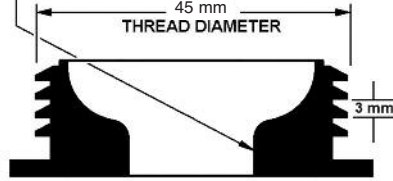

COOLING SYSTEM TANK
THREAD CUTAWAY

Comment: The RA10072 seals with an o-ring just like the cap from the system it tests. In most cases, the RA10025, which seals on the top rim will adequately seal such that pressure testing can be accomplished

APPLICATION:

- ALFA ROMEO®:** Some models with threaded filler necks
- FERRARI®:** 2015 - current
- FIAT®:** Model 500: Some versions with threaded filler necks
- MASERATI®:** Ghibli S Q4 2015-current
- RAM®:** ProMaster 2015-current

RA10074



WHERE O-RING OF CAP SEALS ON COOLANT BOTTLE NECK

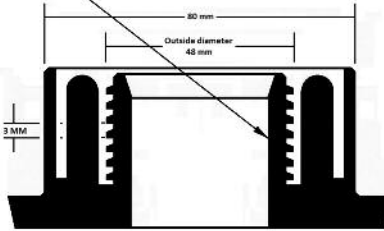

APPLICATION:

- BENTLEY®:** Some Models
- VOLKSWAGEN®:** Sharan (EU) Phaeton 2004-2006 (US)



RA10078

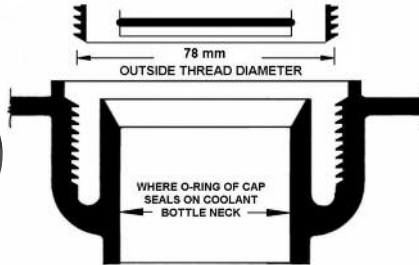

APPLICATION:

- PORSCHE®:** Some Models



RCA1C087

RA10086



WHERE GASKET OF CAP SEALS ON COOLANT BOTTLE NECK

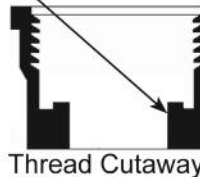
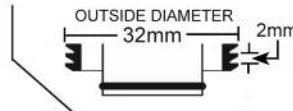

APPLICATION:

- HYUNDAI®:** Models with threaded filler neck
- KIA®:** Sportage 2016 - current Niro 2017 - current



RCA1C089

RA10088



WHERE O-RING OF CAP SEALS ON COOLANT BOTTLE NECK

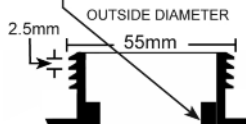

APPLICATION:

- VOLVO®:** XC40 2018 - current XC90T8 Hybrid-2016-current



RA10093

RA10092

Left
Hand
Thread

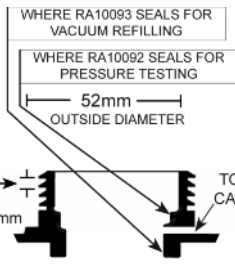

APPLICATION:
CHEVROLET®: Silverado with Duramax® Engine: 2017-current
GMC® Sierra pick-up with Duramax® engine 2017-current
 Use RA10092 for pressure testing.
 Use RA10093 for vacuum refilling.

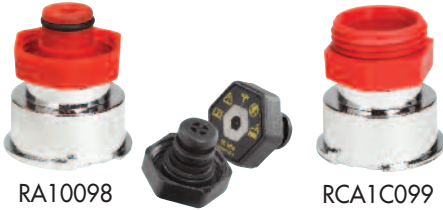

RA10098

RCA1C099

WHERE O-RING OF CAP SEALS IN COOLANT BOTTLE NECK

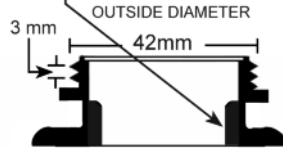

APPLICATION:
TESLA®: Tesla Model 3



RCA1C047

RA10245

WHERE GASKET OF CAP SEALS ON COOLANT BOTTLE NECK

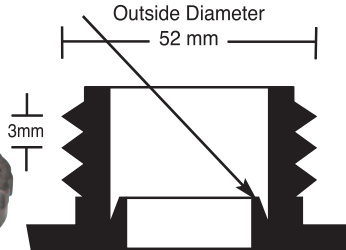

Thread Cutaway

APPLICATION:
BMW®: models with threaded filler necks (up to 1987) 325: up to 1991 525: up to 1993
MERKUR® SCORPIO: (1987-1989)
Comments: Rubber gasket seals on "shelf" inside expansion tank neck



RA1C346

RA10345

WHERE GASKET OF CAP SEALS ON COOLANT BOTTLE NECK

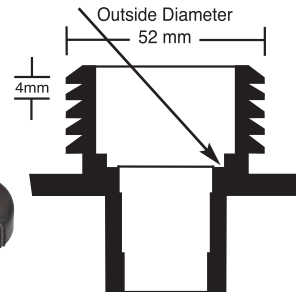

APPLICATION:
BMW®: Most Models, 1998-2008
LAND ROVER®: Some models with male threads on filler neck (see page 15) Discovery 1999-2004 Range Rover 1996-2006
Comments: Rubber gasket seals on "shelf" inside expansion tank neck



RCA1C446

RA10445

WHERE GASKET OF CAP SEALS ON COOLANT BOTTLE NECK

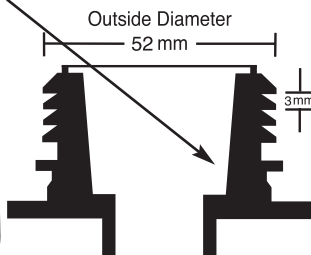

Thread Cutaway

APPLICATION:
BMW®: Most BMW models, 2007-current
 3-Series 2006-current
 5-Series 2005-current
 6-Series 2005-current
 X3 2009-current
 X5 2009-current
 X6 2008-current

MOST ASIAN VEHICLES - MOTORCYCLES - FORKLIFTS - TOYOTA® SIENNA VAN

Remote adapter allows pressure pump or vacuum refiller to be installed in various low overhead applications.

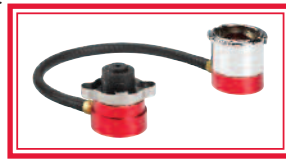

RA10128R

Most motorcycles, including the Harley Davidson® liquid cooled models, use this configuration.



RCA1C029



RA10128

ROUNDED EARS

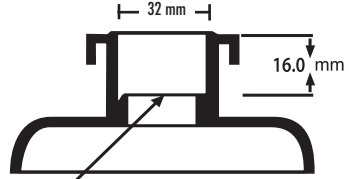

WHERE GASKET OF CAP MEETS RADIATOR NECK



RCA1C039



RA10138

SQUARE EARS

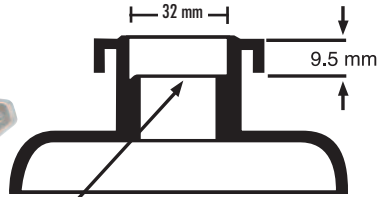

WHERE GASKET OF CAP MEETS RADIATOR NECK

Comments: The RA10128/RCA1C029 and the RA10138/RCA1C039 have applications too numerous to list here. See Application Guide pp 12-18. These adapter sets are quite similar, but the RA10128/RCA1C029 is a deeper neck than the RA10138/RCA1C039. See drawings above, right.

Note: RA10128 AND RA10138 are shaped to resemble caps from system to be tested.



UCT700-4

UCT700-6

WHERE GASKET OF CAP MEETS RADIATOR NECK

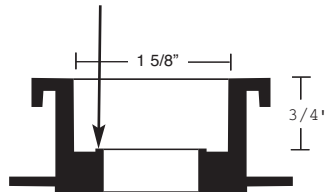

APPLICATION:

Most passenger vehicles through the mid 1980's have this radiator neck and many still do today. This is the configuration onto which the pump attaches directly.

LARGE TRUCKS / BUSES / HEAVY EQUIPMENT

RCA1C023



RA10022



WHERE GASKET OF CAP SEALS ON COOLANT BOTTLE NECK

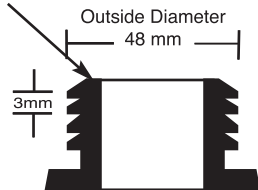

APPLICATION:

MACK® TRUCKS:
2008 and later with
48mm x 3mm threads
on filler neck

VOLVO®:

Large Trucks with
48mm x 3mm male
thread on filler neck

RA10027



WHERE GASKET OF CAP SEALS ON COOLANT BOTTLE NECK

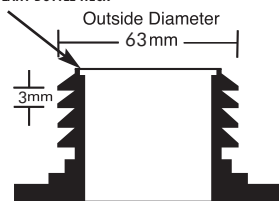

APPLICATION:

VOLVO®:

Large Trucks with
63mm x 3mm thread
on filler neck



RA10042



WHERE GASKET OF CAP SEALS ON COOLANT BOTTLE NECK

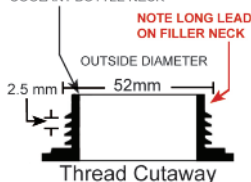

APPLICATION:

KENWORTH®:

T660 and T680 Trucks



RA10054



WHERE GASKET OF CAP SEALS ON COOLANT BOTTLE NECK

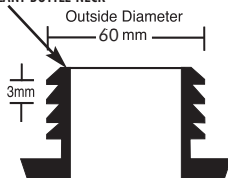

APPLICATION:

FREIGHTLINER®:

Trucks with
60mm x 3mm male
thread on filler neck



RA10076



Note: Cap and adapter have 3 tabs

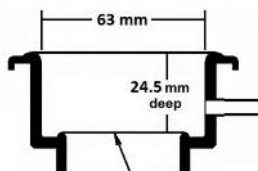

WHERE GASKET OF CAP SEALS ON COOLANT SYSTEM NECK

Thread Cutaway

APPLICATION:

LIEBHERR® CRANE:

Some models

VAN HOO® BUS:

Some models

LARGE TRUCKS / BUSES / HEAVY EQUIPMENT

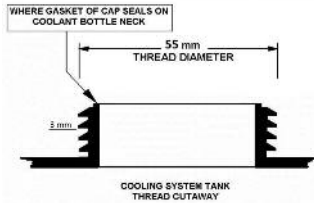

APPLICATION:

KENWORTH®:

2015-current

T270

T370



WHERE GASKET OF CAP SEALS ON COOLANT BOTTLE NECK

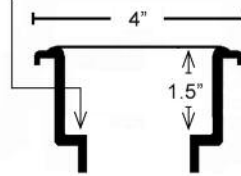

APPLICATION:

INDUSTRIAL APPLICATIONS:

With a 4 inch neck



WHERE GASKET OF CAP MEETS RADIATOR NECK (RA1450S)

WHERE GASKET OF CAP MEETS RADIATOR NECK (RA1450S)

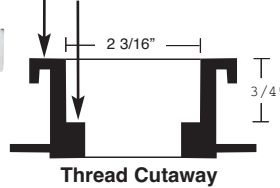

PART #RA14503: GM adapter tests pressure on "closed cooling systems" on GM 2.5L "X" body cars and 1.8L "J" body cars

RA1450S and RCA1450A:
Adapters for trucks with "B" size 2 11/16" O.D. filler neck



WHERE GASKET OF CAP SEALS ON COOLANT BOTTLE NECK

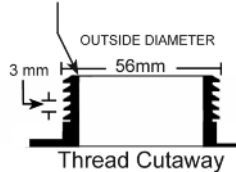

APPLICATION:

VOLVO®:

Volvo FH4 trucks and A45G Haul Trucks



WHERE GASKET OF CAP SEALS ON COOLANT BOTTLE NECK

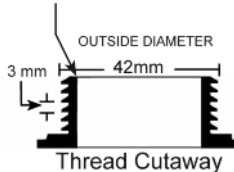

APPLICATION:

VOLVO®:

Volvo EC220E Excavator



WHERE GASKET OF CAP SEALS ON COOLANT BOTTLE NECK

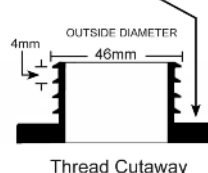

APPLICATION:

JOHN DEERE®:

Some John Deere tractors

COOLING SYSTEM ADAPTERS

Interactive Adapter search:
www.mactoolsradiatorstools.com

| Make/Model/Year | Cooling System Adapter | Cap Adapter |
|--|------------------------|-------------|
| ACURA® | | |
| Models with 16mm deep filler neck, see page 9 | RA10128 | RCA1C029 |
| Models with 9.5mm deep filler neck, see page 9 | RA10138 | RCA1C039 |
| ALFA ROMEO® | | |
| Some models 2014-current | RA10072** | RCA1C026 |
| ASTON MARTIN® | | |
| 6.0L, V-12 2015-current | RA10052 | RCA1C05 |
| Various Models 2005-current | RA10046 | RCA1C047 |
| AUDI® | | |
| Models with male threads on filler neck of exp. tank | RA10022 | RCA1C023 |
| Models with female threads on filler neck of exp. tank | RA10041 | RCA1C040 |
| BLUEBIRD® BUS | | |
| Late model Thomas Built buses | RA10036 | RCA1C035 |
| BMW® | | |
| Models with threaded filler neck | | |
| Up to 1987 | RA10245 | RCA1C047 |
| 1988 & Newer, (except as noted) | RA10345 | RCA1C346 |
| Most models after 2006 | RA10445 | RCA1C446 |
| Model 325 | | |
| 1988-1991 | RA10245 | RCA1C047 |
| Model 535 | | |
| 1989-1993 | RA10245 | RCA1C047 |
| 5&6 Series | | |
| 2005-current | RA10445 | RCA1C446 |
| 1 Series | | |
| 2008-current | RA10445 | RCA1C446 |
| 3 Series | | |
| 1990-2006 | RA10345 | RCA1C346 |
| 2005-current | RA10445 | RCA1C446 |
| Turbocharger cooling sys (all) | RA10063▲ | RCA1C026 |
| 5 Series | | |
| 1998-2004 | RA10345 | RCA1C346 |
| 2005-current | RA10445 | RCA1C446 |
| Turbocharger cooling sys (all) | RA10063▲ | RCA1C026 |
| 6 Series | | |
| 2004-current | RA10445 | RCA1C446 |
| Turbocharger cooling sys (all) | RA10063▲ | RCA1C026 |
| 7 Series | | |
| 1994-2008 | RA10345 | RCA1C346 |
| 2008-current | RA10445 | RCA1C446 |
| Turbocharger cooling sys (all) | RA10063▲ | RCA1C026 |

| Make/Model/Year | Cooling System Adapter | Cap Adapter |
|---|--------------------------------|----------------------------------|
| BMW® | | |
| X1 2009-2011 | RA10345 | RCA1C346 |
| X3 2004-7/2009 7/2009 | RA10345 RA10445 | RCA1C346 RCA1C446 |
| X5 2000-2008 2009-current Turbocharger cooling sys (all) | RA10345 RA10445 RA10063▲ | RCA1C346 RCA1C446 RCA1C026 |
| X6 2008-current Turbocharger cooling sys (all) | RA10445 RA10063▲ | RCA1C446 RCA1C026 |
| Z3 2002 | RA10345 | RCA1C346 |
| Z4 2003-2008 2009-current | RA10345 RA10445 | RCA1C346 RCA1C446 |
| Z8 2003 | RA10345 | RCA1C346 |
| BUICK® | | |
| All Models w/male threads on filler neck except as noted below | RA10036* | RCA1C035 |
| Skyhawk 1982-1987 1.8L & 2.0L | RA14503 | |
| Skylark 1982-1988 2.5L 1992-1998 | RA14503 RA10036* | RCA1C035 |
| Somerset 1985-1987 2.5L | RA14503 | |
| CADILLAC® | | |
| All Models w/male threads on filler neck except as noted below | RA10036* | RCA1C035 |
| Catera 1997-2001 | RA10034 | RCA1C047 |
| STS, CTS, ATS 2005-current Engine Cooling System Supercharger Cooling System | RA10036 RA10056 | RCA1C035 RCA1C057 |

**RA10025 may also work.

▲RA10063 seals the same way the radiator cap seals but the RA10025 will work in most applications.

*If RA10036 "Stem" with O-ring will not fit into cooling system neck, the RA10032 may be required.

COOLING SYSTEM ADAPTERS

Interactive Adapter search:
www.mactoolsradiatortools.com

| Make/Model/Year | Cooling System Adapter | Cap Adapter |
|--|-------------------------------|----------------------------------|
| CHEVROLET® | | |
| All Models w/male threads on filler neck except as noted below | RA10036* | RCA1C035 |
| Aveo 2004-2011 | RA10034 | RCA1C047 |
| Beretta 1992-1996 | RA10036* | RCA1C035 |
| Bolt 2017-current | | |
| Citation 1982-1985 2.5L | RA14503 | |
| | RCA1C057 | |
| Cobalt 2005-2010 Engine Cooling System Supercharger Cooling System | RA10036 RA10056 | RCA1C035 RCA1C057 |
| Impala 1994-1996 | RA10036* | RCA1C035 |
| | RA10036 | RCA1C035 |
| Lumina 1990-1992 | RA14503 | |
| Metro 1998-2001 | RA10138 | RCA1C039 |
| Nova 1985-1988 | RA10128 | RCA1C029 |
| Prizm 1998-2002 | RA10138 | RCA1C039 |
| Silverado with Duramax (LSP diesel) engine 2017-current (pressure testing) 2017-current (vacuum filling) | RA10092 RA10093 | |
| Spectrum 1985-1989 | RA10128 | RCA1C029 |
| Sprint 1985-1988 | RA10128 | RCA1C029 |
| Tracker 1998-2004 | RA10138 | RCA1C039 |
| Volt 2012-current Electric Motor Battery System Gasoline Engine | RA10056 RA10056 RA10036 | RCA1C057 RCA1C057 RCA1C035 |
| CHRYSLER®/DODGE®/EAGLE®/PLYMOUTH®/RAM® | | |
| 200 2015-current | RA10036 | RCA1C035 |
| 1500 with eTorque 2018 - current | RA10056 | RCA1C057 |
| 2000 GTX 1989-1990 | RA10128 | RCA1C029 |
| Avenger 1995-1999 | RA10128 | RCA1C029 |
| Colt 1984-1993 1992-1994 (some models) | RA10128 RA10138 | RCA1C029 RCA1C039 |
| Conquest 1984-1989 | RA10128 | RCA1C029 |
| Crossfire 2004-2008 | RA10044 | RCA1C045 |
| Dart 2013-current | RA10036 | RCA1C035 |
| Laser/Talon 1990-1998 | RA10128 | RCA1C029 |

| Make/Model/Year | Cooling System Adapter | Cap Adapter |
|---|--------------------------------|----------------------------------|
| CHRYSLER®/DODGE®/EAGLE®/PLYMOUTH®/RAM® | | |
| Pacifica 2017-current Engine Cooling System Electric Motor | RA10036 RA10056 | RCA1C035 RCA1C057 |
| Promaster 2014-current | RA10072** | RCA1C026 |
| RAM 50 Pickup 1987-1993 | RA10128 | RCA1C029 |
| RAM 1500 with eTorque 2018-current | RA10056 | RCA1C057 |
| RAM Pickup (some models) 2013-current | RA10036 | RCA1C035 |
| Sebring 2003-2005 6c 3.0L & 4c 2.4L 2001, 2002-2006 | RA10138 none | RCA1C039 UCT700-6 |
| Sprinter Van 2007-2010 | RA10058 | RCA1C059 |
| Stealth 1991-1996 | RA10128 | RCA1C029 |
| Stratus (3.0 liter only) 2001-2006 | RA10138 | RCA1C039 |
| Summit 1989-1992 1992-1996 | RA10128 RA10138 | RCA1C029 RCA1C039 |
| Talon 1990-1998 | RA10128 | RCA1C029 |
| DAEWOO® | | |
| All 1999-2002 | RA10034 | RCA1C047 |
| FERRARI® | | |
| Most Models 2000-current | RA10025 | RCA1C026 |
| FIAT® | | |
| 500 2015-current | RA10072** | RCA1C026 |
| FORD®/LINCOLN®/MERCURY® | | |
| All Models w/male threads on filler neck except as noted below | RA10036* | RCA1C035 |
| Aspire 1994-1997 | RA10128 | RCA1C029 |
| C-Max 2013-current | RA10052 | RCA1C053 |
| Contour 1995-1997 1998-2000 | RA10034 RA10046 | RCA1C047 RCA1C047 |
| Cougar/Thunderbird 1989-1992 1993-1997 V8 1993-1997 V6 | RA10128 RA10036* RA10128 | RCA1C029 RCA1C035 RCA1C029 |
| Ecosport 2013-current | RA10052 | RCA1C053 |
| Edge 2015-current | RA10052 | RCA1C053 |
| Escape 2001-2012 2013-current | RA10046 RA10052 | RCA1C047 RCA1C053 |

* If RA10036 "Stem" with O-ring will not fit into cooling system neck, the RA10032 may be required.

**RA10025 will work in most applications

COOLING SYSTEM ADAPTERS

Interactive Adapter search:
www.mactoolsradiatorstools.com

| Make/Model/Year | Cooling System Adapter | Cap Adapter |
|--|------------------------|-------------|
| FORD®/LINCOLN®/MERCURY® | | |
| Escort/Tracer 1991-2012 | RA10128 | RCA1C029 |
| Explorer/Mountaineer/Aviator 1995-2002 | RA10128 | RCA1C029 |
| 2002-current | RA10036* | RCA1C035 |
| F Series pick-up 2015-current | RA10052 | RCA1C053 |
| Festiva 1988-1993 | RA10128 | RCA1C029 |
| Fiesta 2011-current | RA10052 | RCA1C053 |
| Focus 2000-2004 | RA10034 | RCA1C047 |
| 2005-2007 | RA10036* | RCA1C035 |
| 2008-2011 | RA10128 | RCA1C029 |
| 2012-current | RA10052 | RCA1C053 |
| Fusion 2006-2012 | RA10036* | RCA1C035 |
| 2013-current | RA10052 | RCA1C053 |
| LS 2002-2006 | RA10034 | RCA1C047 |
| MKC 2015-current | RA10052 | RCA1C053 |
| Mustang V8, 1996-2014 | RA10036* | RCA1C035 |
| V6, 1997-2004 | RA10128 | RCA1C029 |
| V6, 2005-2014 | RA10036* | RCA1C035 |
| V6 and V8 2015-current | RA10052 | RCA1C053 |
| Probe 1989-1997 | RA10128 | RCA1C029 |
| Ranger Pickup 1995-current (non threaded neck) | RA10128 | RCA1C029 |
| 2002-current (threaded neck) | RA10036* | RCA1C035 |
| Tempo/Topaz 1992-1994 | RA10128 | RCA1C029 |
| Thunderbird 1989-1993 (All) | RA10128 | RCA1C029 |
| 1994-1997 (V6) | RA10128 | RCA1C029 |
| 1994-1997 (V8) | RA10036* | RCA1C035 |
| 2002-2004 (V8) | RA10036* | RCA1C035 |
| Transit Connect 2010-2012 | RA10034 | RCA1C047 |
| 2013-current | RA10052 | RCA1C053 |
| Villager 1993-2002 | RA10128 | RCA1C029 |
| Windstar 1995-2000 | RA10128 | RCA1C029 |
| 2000-2003 | RA10036* | RCA1C035 |
| ZX2 2001-2003 | RA10128 | RCA1C029 |

| Make/Model/Year | Cooling System Adapter | Cap Adapter |
|--|------------------------|-------------|
| FREIGHTLINER® | | |
| Trucks with: 60mm x 3mm male thread 52mm x 2.5mm male thread | RA10054 | |
| Cascadia 2007-current | RA10032 | RCA1C035 |
| Century, Columbia 2002-current | RA10036 | RCA1C035 |
| GEO® | | |
| Metro 1989-1994 | RA10128 | RCA1C029 |
| 1995-1998 | RA10138 | RCA1C039 |
| Prizm 1989-1992 | RA10128 | RCA1C029 |
| 1993-2002 | RA10138 | RCA1C039 |
| Storm 1990-1993 | RA10128 | RCA1C029 |
| Tracker 1989-1993 | RA10128 | RCA1C029 |
| 1994-2004 | RA10138 | RCA1C039 |
| GMC® | | |
| All Models w/male threads on filler neck | RA10036 | RCA1C035 |
| Sierra w/ Duramax engine 2017-current (pressure testing) | RA10092 | |
| 2017-current (vacuum filling) | RA10093 | |
| HONDA® | | |
| Models with 16mm deep filler neck, see page 9 | RA10128 | RCA1C029 |
| Models with 9.5mm deep filler neck, see page 9 | RA10138 | RCA1C039 |
| HUMMER® | | |
| All Models w/male threads on filler neck | RA10036 | RCA1C035 |
| HYUNDAI® | | |
| Models with 16 mm deep filler neck, see page 9 | RA10128 | RCA1C029 |
| Models with threaded filler neck | RA10086 | RCA1C087 |
| INDUSTRIAL | | |
| Various industrial applications (see page 11 for specs) | RA10090 | |
| INTERNATIONAL® | | |
| 466 Engine with male threads on filler neck 1994-1998 | RA10032 | RCA1C035 |

* If RA10036 "Stem" with O-ring will not fit into cooling system neck, the RA10032 may be required.

COOLING SYSTEM ADAPTERS

Interactive Adapter search:
www.mactoolsradiatortools.com

| Make/Model/Year | Cooling System Adapter | Cap Adapter |
|---|------------------------|----------------------|
| INFINITI® | | |
| All Models with Non-Threaded Small Cooling System Caps (see page 9) | RA10128 | RCA1C029 |
| QX30 2017-current | RA10044 | RCA1C045 |
| QX50 2019-current | RA10063 | RCA1C026 |
| QX56 2004-2009 2010-current | RA10036* RA10128 | RCA1C035 RCA1C029 |
| ISUZU® | | |
| All models except as noted below 1985-2009 | RA10128 | RCA1C029 |
| Amigo 1999-2000 (L-4 only) | RA10138 | RCA1C039 |
| Ascender 2002-2009 | RA10036 | RCA1C035 |
| i280 2006 | RA10036 | RCA1C035 |
| i290 2007-2008 | RA10036 | RCA1C035 |
| i350 2006 | RA10036 | RCA1C035 |
| i370 2007-2008 | RA10036 | RCA1C035 |
| Oasis 1996-1999 | RA10138 | RCA1C039 |
| Rodeo 1998-2003 (L-4 only) | RA10138 | RCA1C039 |
| JAGUAR® | | |
| Models with male threads on filler neck 1990-1994 | RA10034 | RCA1C047 |
| E-Pace 2018-current | RA10052 | RCA1C053 |
| F-Type 2013-current | RA10036 | RCA1C035 |
| XF 2009-current | RA10036* | RCA1C035 |
| XX8 1997-2004, 2006 | RA10046 | RCA1C047 |
| XX8 1998-2003 2004-2009 | RA10046 RA10036* | RCA1C047 RCA1C035 |
| S-Type 2000-2008 | RA10036* | RCA1C035 |
| X-Type 2009-current | RA10034 | RCA1C047 |
| JEEP® | | |
| Models with male threads on filler neck 1987-1990 | RA10025 | RCA1C026 |
| Cherokee 2014-current | RA10036 | RCA1C035 |
| Renegade 2015-current | RA10036 | RCA1C035 |
| Wrangler 2018-current with eTorque | RA10036 | RCA1C035 |
| 2018-current | RA10056 | RCA1C057 |

* If RA10036 "Stem" with O-ring will not fit into cooling system neck, the RA10032 may be required.

| Make/Model/Year | Cooling System Adapter | Cap Adapter |
|---|------------------------|-------------|
| JOHN DEERE® TRACTORS | | |
| Most model #'s over 3000 with 48mm O.D. male threads on filler neck | RA10022 | RCA1C023 |
| Some model #'s over 3000 with 52mm O.D. male threads on filler neck | RA10102 | N/A |
| Some Models | RA10102 | |
| KENWORTH® TRUCKS | | |
| Some Models 2007-current T270, T370 | RA10032 | RCA1C035 |
| 2015-current | RA10084 | |
| T660 | | |
| 2008-2017 | RA10042 | |
| T680 | | |
| 2014-current | RA10042 | |
| KIA® | | |
| Models with 16mm deep filler neck, see page 9 | RA10128 | RCA1C029 |
| Sportage 2016-current | RA10086 | RCA1C087 |
| Niro 2017-current | RA10086 | RCA1C087 |
| LAND ROVER® | | |
| Defender 1993-1995, 1997 | RA10034 | RCA1C047 |
| Discovery 1998 | RA10034 | RCA1C047 |
| 1999-2004 | RA10345 | RCA1C346 |
| Freelander 2002-current | RA10025 | RCA1C026 |
| LR2 2008-current | RA10052 | RCA1C053 |
| LR3 2005-current | RA10036* | RCA1C035 |
| LR4 2010-2016 | RA10036* | RCA1C035 |
| Range Rover 1988-1994 | RA10034 | RCA1C047 |
| 1995-2005 | RA10345 | RCA1C346 |
| 2006-2015 | RA10036* | RCA1C035 |
| Range Rover Evoque 2012-current | RA10052 | RCA1C053 |
| Velar 2018-current | RA10032 | RCA1C035 |
| LEXUS® | | |
| Models with 16mm deep filler neck, see page 9 | RA10128 | RCA1C029 |
| Models with 9.5mm deep filler neck, see page 9 | RA10138 | RCA1C039 |
| Models with Threaded Caps: | | |
| GS 460 2008-2011 | RA10048 | RCA1C049 |
| HS 250h 2010-current | RA10048 | RCA1C049 |
| IS F 2008-2014 | RA10048 | RCA1C049 |
| LS 2007-current | RA10048 | RCA1C049 |
| NX 2015-current | RA10048 | RCA1C049 |

COOLING SYSTEM ADAPTERS

Interactive Adapter search:
www.mactoolsradiatorstools.com

| Make/Model/Year | Cooling System Adapter | Cap Adapter |
|--|------------------------|-------------|
| LIEBHERR® CRANE | | |
| Some models | RA10076 | |
| MACK® | | |
| Later models with male threads on filler neck | RA10022 | RCA1C023 |
| MASERATI® | | |
| Most Models | | |
| 2000-current | RA10025 | RCA1C026 |
| Ghibli S Q4 | | |
| 2015-current | RA10072** | RCA1C026 |
| MAZDA® | | |
| Models with 16mm deep filler neck, see page 9 | RA10128 | RCA1C029 |
| Models with 9.5mm deep filler neck, see page 9 | RA10138 | RCA1C039 |
| Models with Threaded Caps: | | |
| B2300 Pickup | | |
| 1994-1997 | none | UCT700-6 |
| 2001-2009 | RA10036* | RCA1C035 |
| Tribute | | |
| 2001-2011 | RA10046 | RCA1C047 |
| Mazda 3 | | |
| 2004-current | RA10052 | RCA1C053 |
| Mazda 6 | | |
| 2003-current | RA10036 | RCA1C035 |
| McLAREN® | | |
| Most Models | | |
| 2012-current | RA10072 | RCA1C026 |
| MERCEDES® | | |
| Models with threaded neck except M-Class below | | |
| A-Class | | |
| 2019-current | RA10058 | RCA1C059 |
| B-Class | | |
| 2015-current | RA10058 | RCA1C059 |
| M-Class with threaded neck | | |
| 1998-2005 | RA10036* | RCA1C035 |
| M-Class | | |
| 2006-current | RA10044 | RCA1C045 |
| Sprinter | | |
| 2011-current | RA10058 | RCA1C059 |
| 2019-current | RA10044 | RCA1C045 |
| MERKUR® | | |
| Scorpio | | |
| 1987-1989 | RA10245 | RCA1C047 |
| MINI® | | |
| Cooper S Model | | |
| 2002-current | RA10063▲ | RCA1C026 |
| MITSUBISHI® | | |
| Models with 16mm deep filler neck, see page 9 | RA10128 | RCA1C029 |
| Models with 9.5mm deep filler neck, see page 9 | RA10138 | RCA1C039 |

▲ RA10063 seals the same way the radiator cap seals but the RA10025 will work in most applications.

| Make/Model/Year | Cooling System Adapter | Cap Adapter |
|--|------------------------|-------------|
| NISSAN® | | |
| All models with non-threaded small cooling system caps | | |
| 1987-current | RA10128 | RCA1C029 |
| Armada/Titan | | |
| 2004-2009 | RA10036* | RCA1C035 |
| 2010-2015 | RA10128 | RCA1C029 |
| Kicks | | |
| 2019-current | RA10063 | RCA1C026 |
| Rogue Sport | | |
| 2017-current | RA10063 | RCA1C026 |
| OLDSMOBILE® | | |
| Achieva | | |
| 1992-1998 | RA10036* | RCA1C035 |
| Alero | | |
| 1999-2004 | RA10036 | RCA1C035 |
| Aurora | | |
| 1995-1999 | RA10036* | RCA1C035 |
| Bravada | | |
| 2002-2004 | RA10036 | RCA1C035 |
| Cutlass | | |
| 1997-1998 | RA10036* | RCA1C035 |
| 1999-2004 | RA10036 | RCA1C035 |
| Intrigue | | |
| 1999-2002 | RA10036* | RCA1C035 |
| PETERBILT® TRUCKS | | |
| Some Models 2007-current | RA10032 | |
| PONTIAC® | | |
| Fiero | | |
| 1984-1988 | RA14503 | |
| Firebird | | |
| 1999-2002 | RA10036 | RCA1C035 |
| G3 | | |
| 2009-2010 | RA10034 | RCA1C047 |
| G5 | | |
| 2007-2012 | RA10036 | RCA1C035 |
| G6 | | |
| 2005-2010 | RA10036 | RCA1C035 |
| Grand Am | | |
| 1985-1988 | RA14503 | |
| 1992-2005 | RA10036* | RCA1C035 |
| Grand Prix | | |
| 2004-2008 | RA10036 | RCA1C035 |
| GTO | | |
| 2004-2008 | RA10036* | RCA1C035 |
| Le Mans | | |
| 1988-1993 | RA10034 | RCA1C047 |
| Montana | | |
| 1999-2006 | none | UCT700-6 |
| 2007-2009 | RA10036 | RCA1C035 |
| Optima | | |
| 1988-1991 | RA10036* | RCA1C035 |
| Solstice | | |
| 2006-2009 | RA10036 | RCA1C035 |
| Sunbird | | |
| 1982-1992 | RA14503 | |
| Sunburst | | |
| 1985-1988 | RA10128 | RCA1C029 |
| Sunfire | | |
| 1995-1998 | RA10036* | RCA1C035 |
| 1999-2005 | RA10036 | RCA1C035 |
| Vibe | | |
| 2003-2013 | RA10138 | RCA1C039 |

* If RA10036 "Stem" with O-ring will not fit into cooling system neck, the RA10032 may be required.

**RA10025 will work in most applications

COOLING SYSTEM ADAPTERS

Interactive Adapter search:
www.mactoolsradiatortools.com

| Make/Model/Year | Cooling System Adapter | Cap Adapter |
|--|------------------------|-------------|
| PORSCHE® | | |
| 911 1999-current | RA10022 | RCA1C023 |
| Boxster 1997-2006 | RA10022 | RCA1C023 |
| 2007-2013 | RA10041 | RCA1C040 |
| 2015-current (in luggage compartment) | RA10078 | |
| Cayenne 2003-current | RA10041 | RCA1C040 |
| Cayman 2006 | RA10022 | RCA1C023 |
| 2007-2011 | RA10041 | RCA1C040 |
| 2014-current (in luggage compartment) | RA10078 | |
| Macan 2015-current | RA10041 | RCA1C040 |
| Panamera 2010-current | RA10041 | RCA1C040 |
| RENAULT® | | |
| All models 1985-1987 | RA10025 | RCA1C026 |
| ROLLS ROYCE® | | |
| Ghost 2010 | RA10445 | RCA1C446 |
| Engine cooling system Supercharger cooling system | RA10063 | RCA1C026 |
| SAAB® | | |
| 900 1978-1993 | RA10025 | RCA1C026 |
| 1994-1998 | RA10034 | RCA1C047 |
| 900 Convertible 1994 | RA10025 | RCA1C026 |
| 9000 1986-1998 | RA10025 | RCA1C026 |
| 9-3 1999-2003 | RA10034 | RCA1C047 |
| 2004-2011 | RA10036 | RCA1C035 |
| 9-5 1999-2008 | RA10034 | RCA1C047 |
| 9-7X 2005-2009 | RA10036* | RCA1C035 |
| SATURN® | | |
| All models except as below 1990-1998 | RA10036* | RCA1C035 |
| 1999-2010 | RA10036* | RCA1C035 |
| L - Series 2000-2005 | RA10034 | RCA1C047 |
| Vue 2002 | RA10034 | RCA1C047 |
| 2003-2009 | RA10036 | RCA1C035 |
| Ion Redline Engine Cooling System Supercharger Cooling System | RA10036 | RCA1C035 |
| | RA10056 | RCA1C057 |

| Make/Model/Year | Cooling System Adapter | Cap Adapter |
|---|------------------------|-------------|
| SCION® | | |
| All models 2004 | RA10128 | RCA1C029 |
| XB 2008 | RA10048 | RCA1C049 |
| SMART CAR® | | |
| All models except below: 2008-2015 | RA10022 | RCA1C023 |
| 2016-current | RA10063 | RCA1C026 |
| STERLING® | | |
| All models 1987-1991 | RA10025 | RCA1C026 |
| SUBARU® | | |
| Models with 16mm deep filler neck, see page 9 | RA10128 | RCA1C029 |
| Models with 9.5mm deep filler neck, see page 9 | RA10138 | RCA1C039 |
| SUZUKI® | | |
| Models with 16mm deep filler neck | RA10128 | RCA1C029 |
| Models with 9.5mm deep filler neck EXCEPT BELOW: | RA10138 | RCA1C039 |
| Forenza 2004-2008 | RA10034 | RCA1C047 |
| Reno 2005-2008 | RA10034 | RCA1C047 |
| Verona 2004-2006 | RA10034 | RCA1C047 |
| XL7 2007-2009 | RA10036 | RCA1C035 |

* If RA10036 "Stem" with O-ring will not fit into cooling system neck, the RA10032 may be required.

Laminated adapter application sheet
included with both the CSA1700
and CSA1700A.

• FITS RIGHT INSIDE THE CASE •



Plastic case
available
separately #CSA1700PB

CSA1700 COMPLETE AUTOMOTIVE COOLING SYSTEM TESTER:

CSA1700 will pressure test the cooling systems of all modern cars and light trucks through 2017. Includes UCT700-8 pump and the following 17 adapters: RA10022, RA10025, RA10031, RA10034, RA10036, RA10041, RA10044, RA10046, RA10048, RA10052, RA10056, RA10128, RA10138, RA10245, RA10345, RA10445, and RA14503.

Does not cover 2007- Sprinter Van.

The **CSA1700A** is the above set of cooling system adapters without the UCT700-8 pump. If you are interested in a complete set of **CAP** adapters, see page 20.

CSCA1700: 17 PIECE COOLING SYSTEM CAP ADAPTER SET



- * *Compatible with most pressure pumps on the market.*
- * *17 Adapters (some multi purpose) test the 20 different pressure relieving CAPS found on cooling systems today.*
- * *Adapters, where possible, are shaped to resemble the caps that they test, for example:*



RCA1C023

RCA1C053

Adapters Included in the set are: RCA1C023, RCA1C026, RCA1C029, RCA1C030, RCA1C035, RCA1C039, RCA1C040, RCA1C045, RCA1C047, RCA1C049, RCA1C053, RCA1C057, RCA1C059, RCA1C346, RCA1C446, RCA14504, UCT700-6.

COOLING SYSTEM ADAPTER GASKET APPLICATION GUIDE

(Use gasket part # when ordering replacement gaskets)

| ADAPTER | GASKET/O-RING SIZE | GASKET PART # |
|---|---|---------------|
| RA10034, RA10036 | 1 7/8" O.D. x 1 3/16" I.D. x 1/8" thick | RA10036G |
| RA10245, RA10345 | 1 7/16" O.D. x 15/16" I.D. x 1/16" thick | RA10345G |
| RA10128, RA10138 | 1 1/8" O.D. x 1/2" I.D. x 1/4" thick | RA10128G |
| RA10031, RA10041, RA10074 | 36mm O.D. x 28mm I.D. x 4mm cross section O-ring | RA10041R |
| RA10032, RA10042 | 1 7/8" O.D. x 1 1/16" I.D. x 1/8" thick | RA10032G |
| RA10036, RA10046, RA10052, RA10088, RA10092 | 31mm O.D. x 23mm I.D. x 4mm cross section O-ring | RA10036R |
| RA10044 | 42mm O.D. x 34mm I.D. x 4mm cross section O-ring | RA10044R |
| RA10048 | 13/16" O.D. x 5/8" I.D. x 3/32" cross section O-ring (O-ring # P16) | RA10048R |
| RA10056, RA10098 | 23mm O.D. x 17mm I.D. x 3mm cross section O-ring | RA10056R |
| RA10058 | 27mm O.D. x 21mm I.D. x 3mm cross section O-ring | RA10058R |
| RA10445 | 38mm O.D. x 28mm I.D. x 5mm cross section O-ring | RA10445R |
| RA14503 | 2 3/4" O.D. x 1 3/4" I.D. x 3/16" thick | RA14502 |
| RA14505 | Molded Rubber Gasket | RA14501 |
| RA10025, RA10096 | 1 11/16" O.D. x 1 1/16" I.D. x 1/8" thick | RA10025G |
| RA10022 | 1 3/4" O.D. x 1" I.D. x 1/8" thick | RA10022G |
| RA10027 | 2 3/8" O.D. x 1 5/8" I.D. x 1/8" thick | RA10027G |
| RA10054 | 2 1/4" O.D. x 1 1/2" I.D. x 1/8" thick | RA10054G |
| RA10063, RA10078 | 1 7/16" O.D. x 1 3/16" I.D. x 1/8" cross section O-ring | RA10063R |
| RA10067, RA10067R | Molded Rubber Gasket | RA10067G |
| RA10069 | 1" O.D. x 5/8" I.D. x 3/16" thick | RA10069G |
| RA10070 | 1" O.D. x 1/2" I.D. x 1/16" thick | RA10070G |
| RA10072 | 26mm O.D. x 19mm I.D. x 3.5mm cross section O-ring | RA10072R |
| RA10076 | Molded Rubber Gasket (custom) | RA10076G |
| RA10084, RA10094 | 2 1/16" O.D. x 1 1/8" I.D. x 1/8" thick | RA10084G |
| RA10086 | 21mm O.D. x 14mm I.D. x 7mm cross O-ring | RA10086R |
| RA10090 | Molded Rubber Gasket (custom) | RA10090G |
| RA10093 | 27mm O.D. x 19mm ID x 4mm cross section O-ring | RA10093R |
| RA10096 | 1 1/2" O.D. x 1" I.D. x 1/8" thick | RA10096G |
| RA10102 | 2 3/8" O.D. x 2" I.D. x 3/16" cross (#329) | |

MAR100 COOLANT RETAINER

- PARTS DIAGRAM AND REPLACEMENT PART NUMBERS -

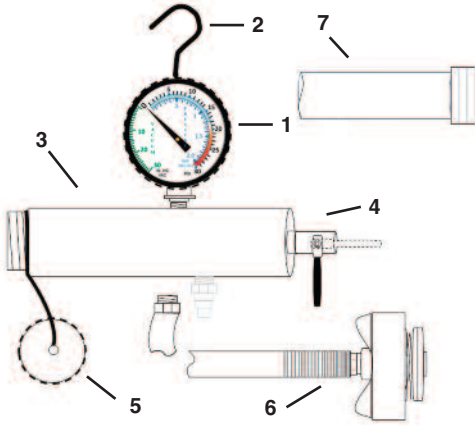

| Number | Part Number | Description |
|-----------|-------------|-------------------------------|
| 1 | MAR100-1 | Dual Gauge |
| 2 | MAR100-2 | Hook Assembly with Nut |
| 3 | MAR100-3 | Venturi Body |
| 4 | MAR100-4 | Air Inlet Valve |
| 5 | MAR100-5 | Brass GHT cap |
| 6 | MAR100-6 | Intake Hose with Cap Assembly |
| 7 | MAR100-7 | Exhaust Hose |
| Not Shown | MAR100-8 | Plastic Box |



CST300 PARTS LIST

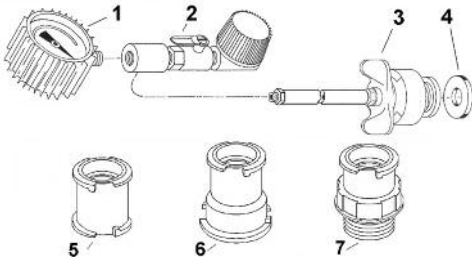

| Diagram # | Stock Part # | Description |
|-----------|--------------|---|
| Not Shown | UCT700-7 | Plastic Carrying Case |
| * | CST300-1 | Complete Pump w/Gauge & Hose Assy. (1-4) |
| 1 | UCT700-1 | Pressure Gauge only |
| 2 | CST300-2 | Valve Regulator Assy. |
| 3 | CST300-3 | Tester Head w/Hose Assembly |
| 4 | UCT700-5 | Tester Seal |
| 5 | UCT700-6 | Cooling System Cap Adapter (A-size) |
| 6 | RCA14504 | Cooling System Cap Adapter (B-size) |
| 7 | RCA1C035 | Cooling System Cap Adapter (52mm x 2.5mm) |

CSR202 & CSR302

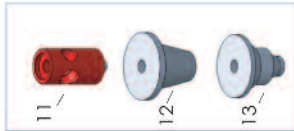
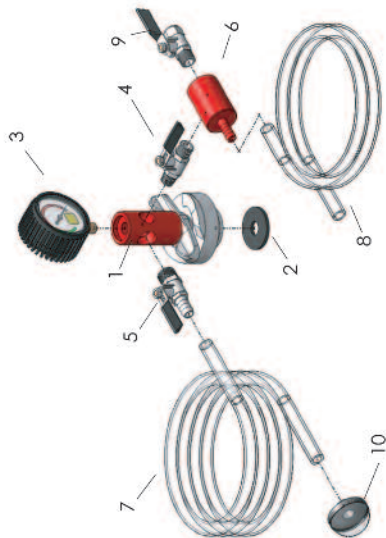

| ITEM | PART # | DESCRIPTION |
|--------------------|-----------|------------------------------------|
| * | CSR200-10 | PLASTIC CASE (not shown) |
| 3 | CSR202-1 | VACUUM GAUGE, LOWER CONNECT |
| 4 | CSR200-6 | ISOLATION VALVE |
| 5 | CSR202-3 | COOLANT REFILL VALVE |
| 6 | CSR200-8 | VENTURI BODY ASSEMBLY |
| 7 | CSR200-4 | COOLANT REFILL HOSE W/SCREEN |
| 8 | CSR200-9 | OVERFLOW HOSE |
| 9 | CSR200-7 | AIR INLET VALVE |
| 10 | CSR200-5 | COOLANT REFILL SUCTION SCREEN ONLY |
| CSR202 ONLY | | |
| 1 | CSR202-2 | COOLANT REFILL BODY ASSEMBLY |
| 2 | UCT700-5 | TESTER SEAL |
| CSR302 ONLY | | |
| 11 | CSR-302-2 | COOLANT REFILL BODY ASSEMBLY |
| 12 | CSR302-4 | ADAPTER CONE, SMOOTH |
| 13 | CSR302-3 | ADAPTER CONE, STEP |

CSR400 Truck Refiller

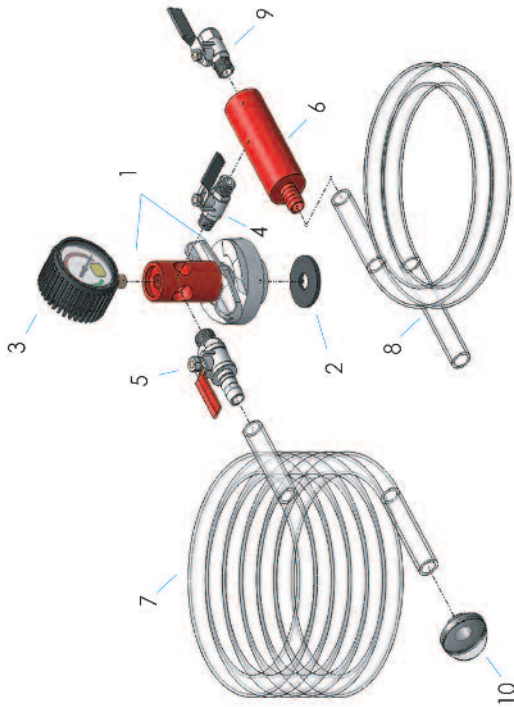

| ITEM | PART # | DESCRIPTION |
|------|-----------|------------------------------------|
| 1 | CSR202-2 | COOLANT REFILL BODY ASSEMBLY |
| 2 | UCT700-5 | TESTER SEAL |
| 3 | CSR202-1 | VACUUM GAUGE, LOWER CONNECT |
| 4 | CSR200-6 | ISOLATION VALVE |
| 5 | CSR400-3 | COOLANT REFILL VALVE |
| 6 | CSR400-8 | VENTURI BODY ASSEMBLY |
| 7 | CSR400-4 | COOLANT REFILL HOSE W/SCREEN |
| 8 | CSR400-9 | OVERFLOW HOSE |
| 9 | CSR200-7 | AIR INLET VALVE |
| 10 | CSR400-5 | COOLANT REFILL SUCTION SCREEN ONLY |
| * | CSR400-10 | PLASTIC CASE |

CST500 Cooling System Tester

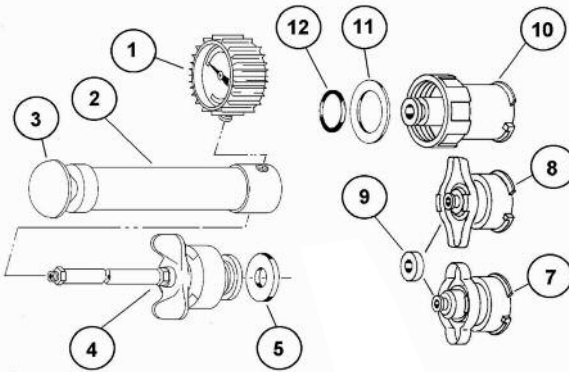

| DIAGRAM # | STOCK PART# | DESCRIPTION |
|-----------|-------------|--|
| * | UCT700-8 | Cooling System Tester Pump (Diagram #1-5) - Packed in a cardboard box. |
| not shown | UCT700-7 | Plastic Carrying Case |
| 1 | UCT700-1 | Heavy Duty Pressure Gauge with Rubber Boot |
| 2 | UCT700-2 | Pump Assembly with Knob (gauge not included) |
| 3 | UCT700-3 | Knob Only |
| 4 | UCT700-4 | Tester Head with Hose Assembly NOTE: Hose may be field repaired - use 3/16" ID fuel hose |
| 5 | UCT700-5 | Tester Seal |
| 7 | RA10128 | 32 mm x 16mm deep Radiator Adapter with Seal, Silver |
| 8 | RA10138 | 32 mm x 9.5mm deep Radiator Adapter with Seal, Gold |
| 9 | RA10128G | Rubber Seal for 32mm Radiator Adapters |
| 10 | RA10036 | Radiator Adapter |
| 11 | RA10036G | Rubber Seal for #RA10036 |
| 12 | RA10036R | Rubber O-Ring for #RA10036 |

CAUTION: TO AVOID PERSONAL INJURY AND/OR VEHICLE DAMAGE – While some precautions are specified in this manual, and should be noted to avoid personal injury or vehicle damage, it is not possible for these cautions to cover all conceivable ways in which service or testing might be done, or all possible hazardous consequences of each way, nor could Mac Tools® possibly know or investigate all such ways. It is therefore the responsibility of anyone using this manual, to satisfy him or herself completely that neither personal safety or vehicle safety will be jeopardized by the service methods selected. Any such injury or damage is entirely the user's responsibility. This device is not to be used in any manner on the human body.